

DWG.NO. HW1385685

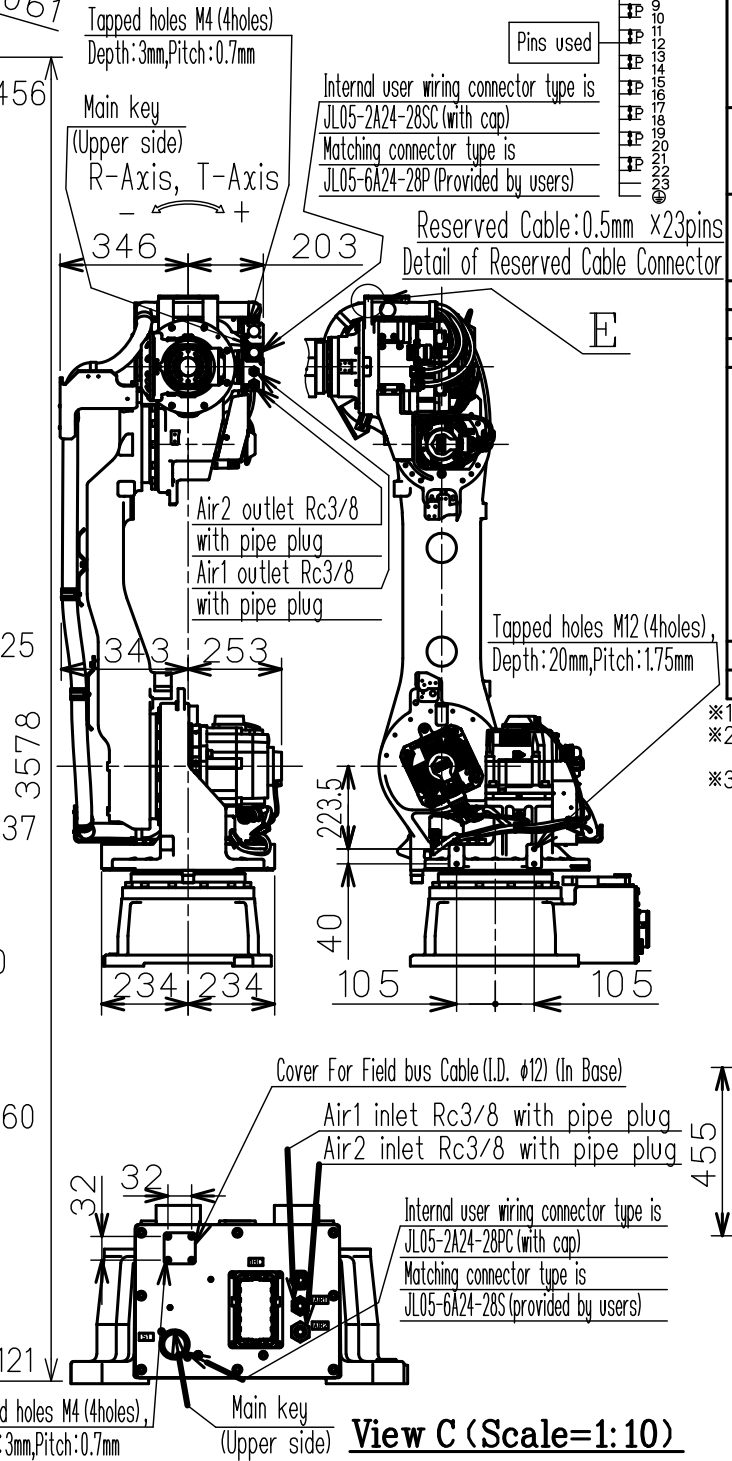

Item	Model	MOTOMAN-GP50
Configuration	Articulated Robot	
Degree of Freedom	6	
Payload	Wrist	50 kg
	On U-arm	10 kg
Repeatability (※1)	±0.07mm	
Range of Motion	S-Axis (※2)	-180° - +180°
	L-Axis	-90° - +135°
	U-Axis	-80° - +206°
	R-Axis	-360° - +360°
	B-Axis	-125° - +125°
	T-Axis	-360° - +360°
Max Speed	S-Axis	3.14rad/s, 180°/s
	L-Axis	3.11rad/s, 178°/s
	U-Axis	3.11rad/s, 178°/s
	R-Axis	4.36rad/s, 250°/s
Allowable Moment	B-Axis	216N·m (22kgf·m)
	T-Axis	147N·m (15kgf·m)
	R-Axis	216N·m (22kgf·m)
Allowable Inertia (GD <sup>2</sup> /4)	R-Axis	28kg·m <sup>2</sup>
	B-Axis	28kg·m <sup>2</sup>
	T-Axis	11kg·m <sup>2</sup>
Approx. Robot mass	570kg	
Protected structure	Body: IP54 Wrist: IP67	
Mounting method (※2)	Floor-mounted, Wall-mounted, Ceiling-mounted	
	Temperature	0 to +45°C
Ambient Conditions	Humidity	20 to 80%RH (Non-condensing)
	Vibration	Less than 4.9m/s <sup>2</sup> (0.5G)
	Altitude	1000m or less
	Others	Free from explosive or corrosive gas and liquid. Free from dust, oil or water. Free from electrical noise. Free from strong magnetic fields.
Power Requirements	4.5KVA	
Controller	YRC1000	

※1 Repeatability is conformed to ISO 9283.  
 ※2 When the manipulator is installed on a slope or a wall, the motion of S-axis will be limited.  
 ※3 The manipulator is in the home position.  
 Units: mm

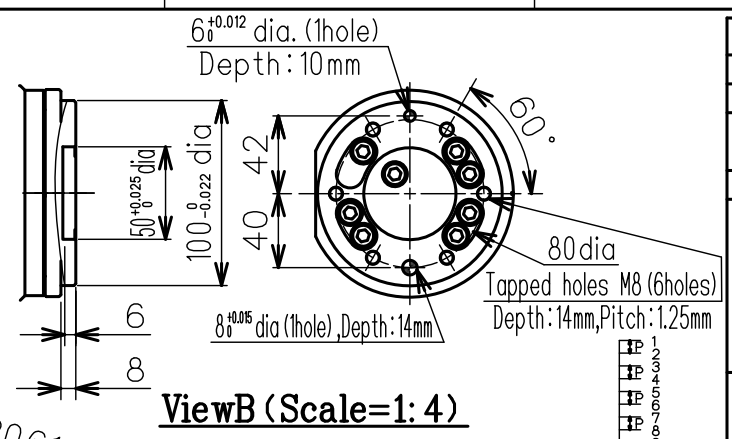
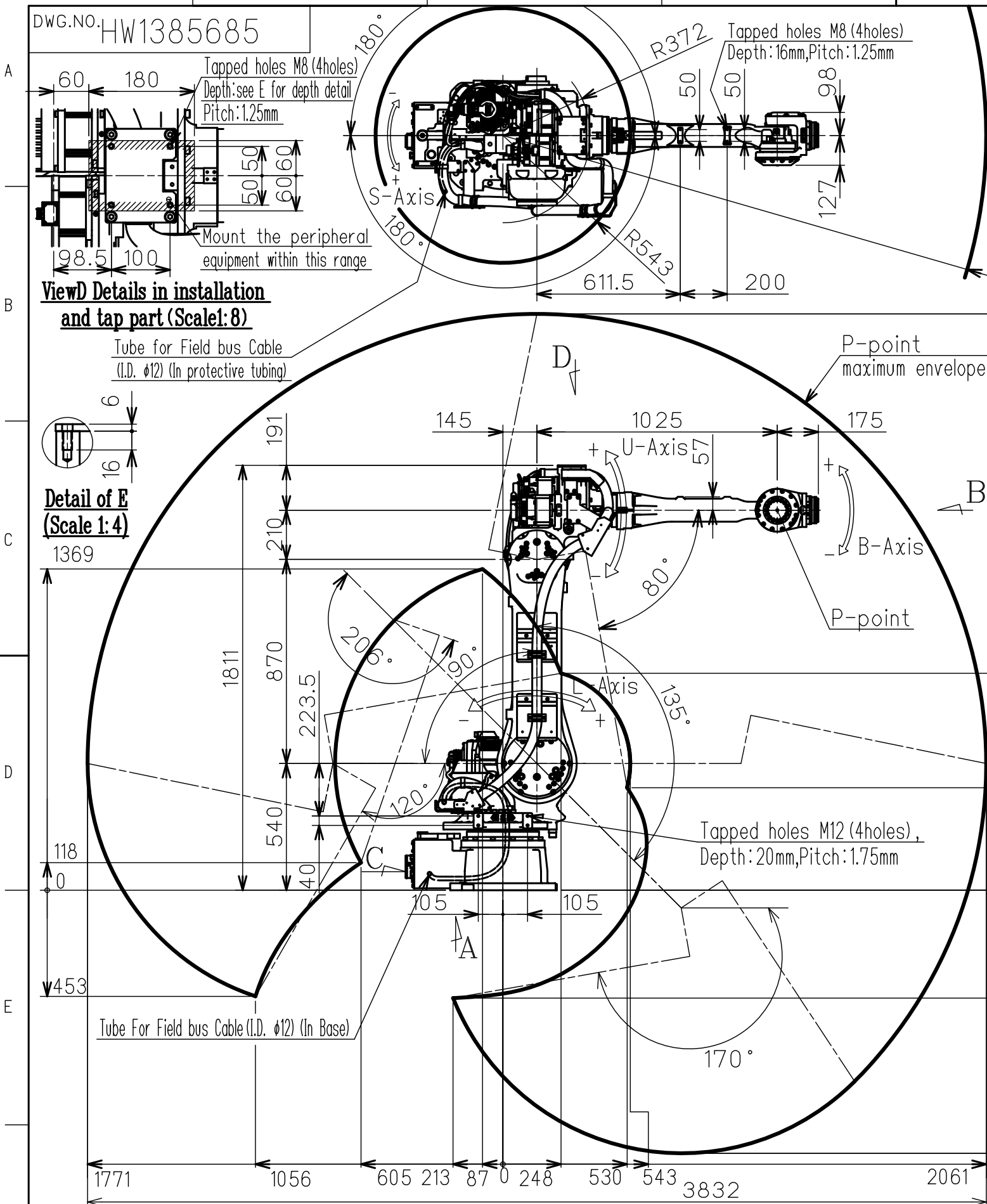
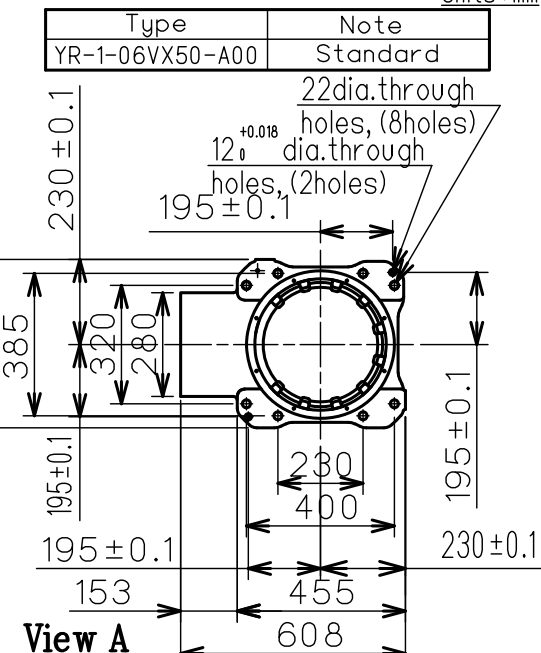

Note:  
 1. All rights reserved.  
 2. Please note that the data is subject to be deleted without advance notice.  
 3. No warranty is given in relation to the data including the specification.  
 4. We are not responsible for any damages or loss caused by the use of the data.

FOR STUDY PURPOSE ONLY

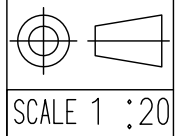

**YASKAWA**  
 株式会社 安川電機

Reference Drawing

TITLE MOTOMAN-GP50  
 DIMENSION DIAGRAM

DRWN DATE Apr. 07. '17  
 DWG.NO. HW1385685

SIZE A3