

DWG.NO. HW1385612

Type	Note
YR-1-06VXH25-A11	STANDARD: Two air lines (built-in high-current power cable)

Tapped holes M4 (8holes), Depth: 8mm
4 $\phi_{0.12}$ dia (1hole), Depth: 6mm

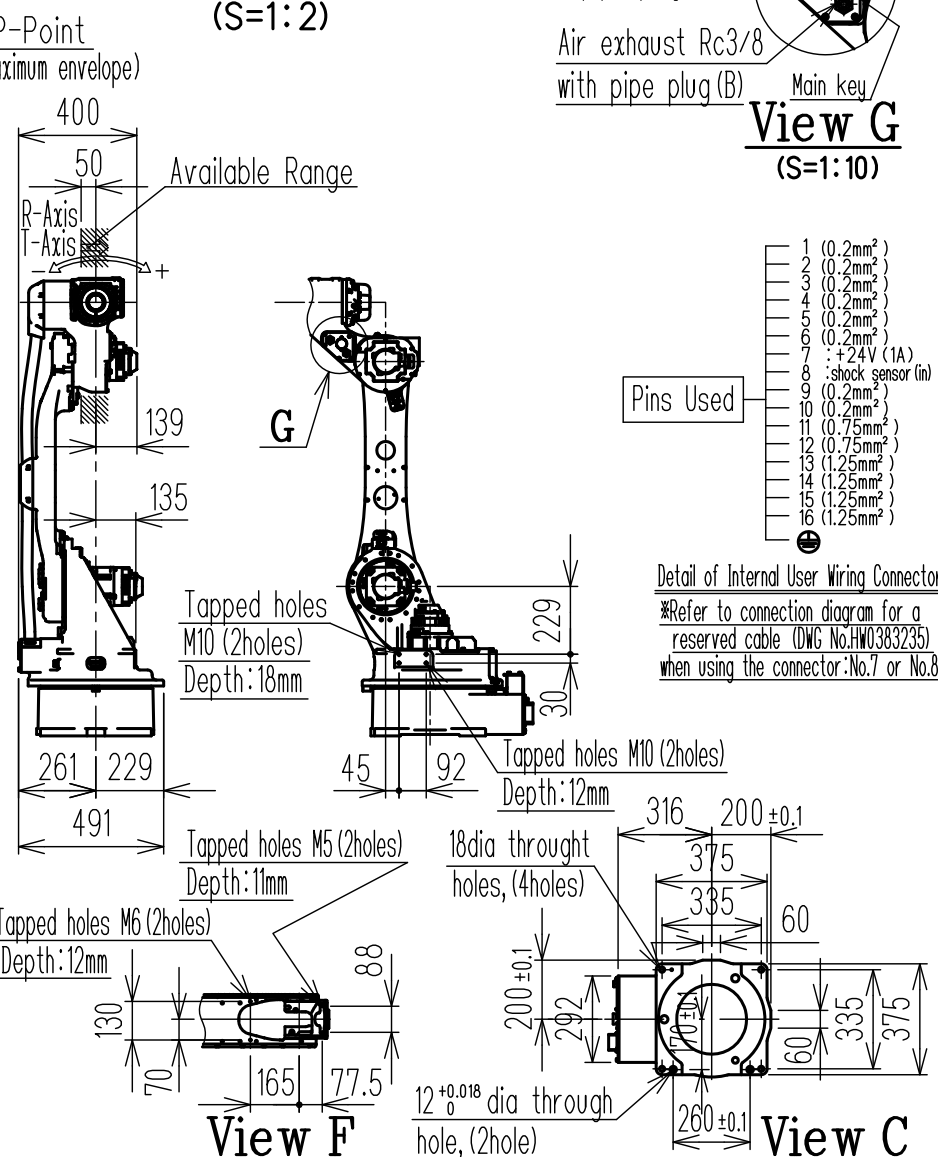
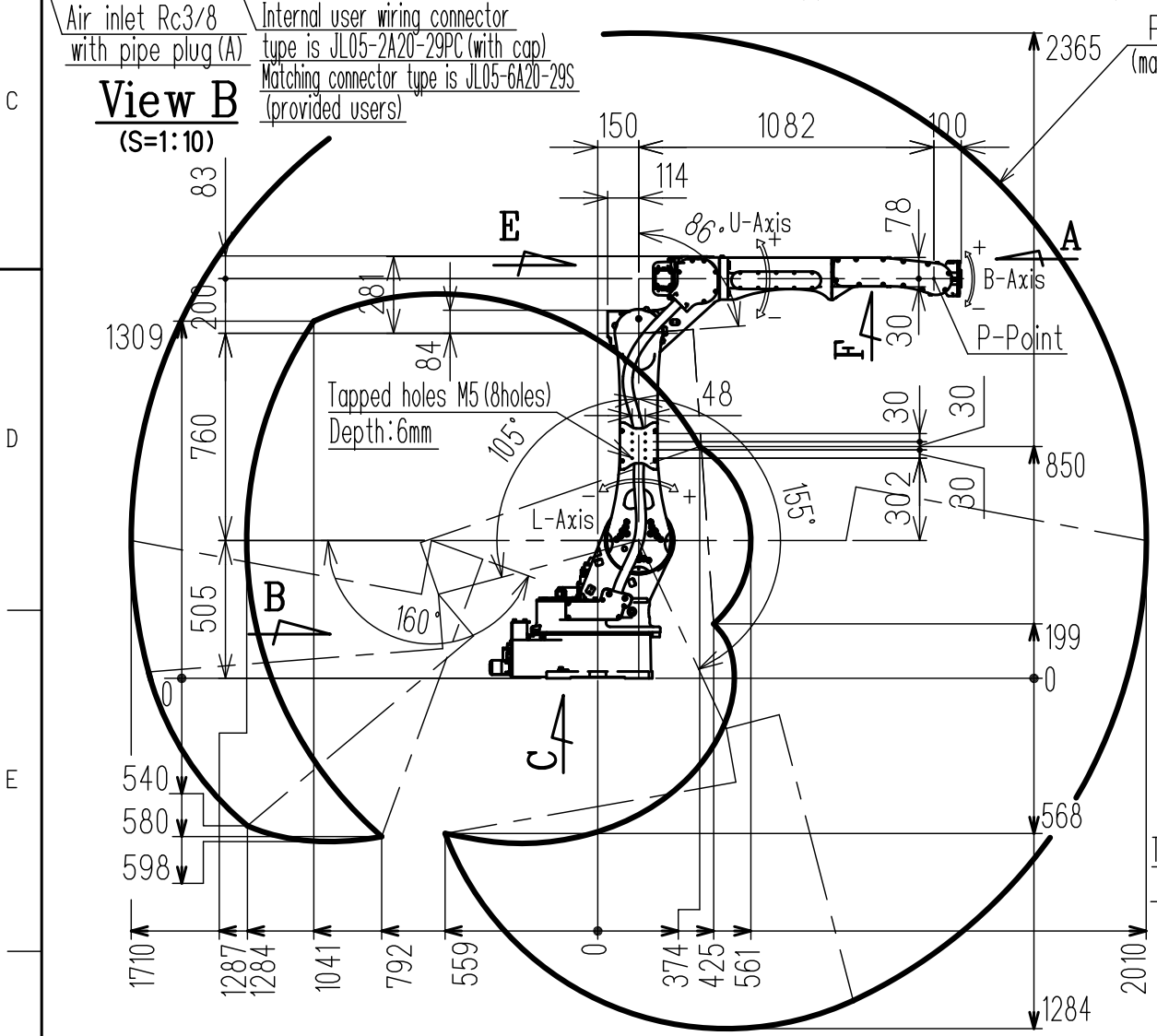
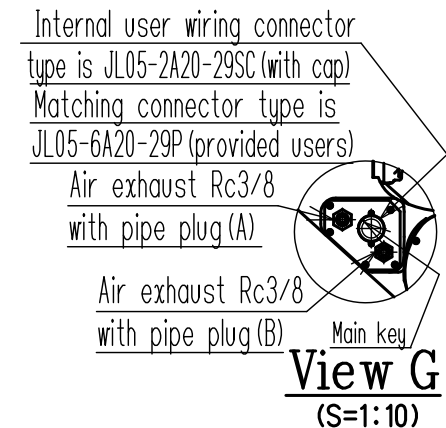
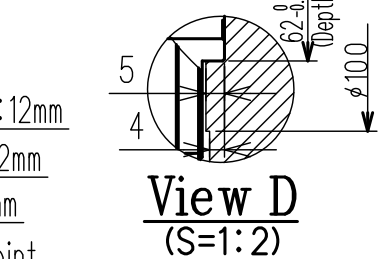
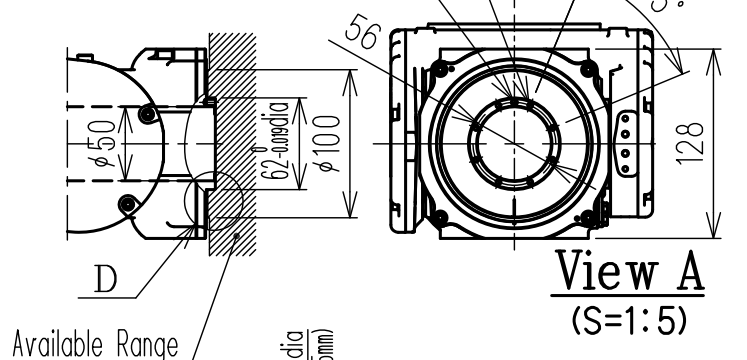
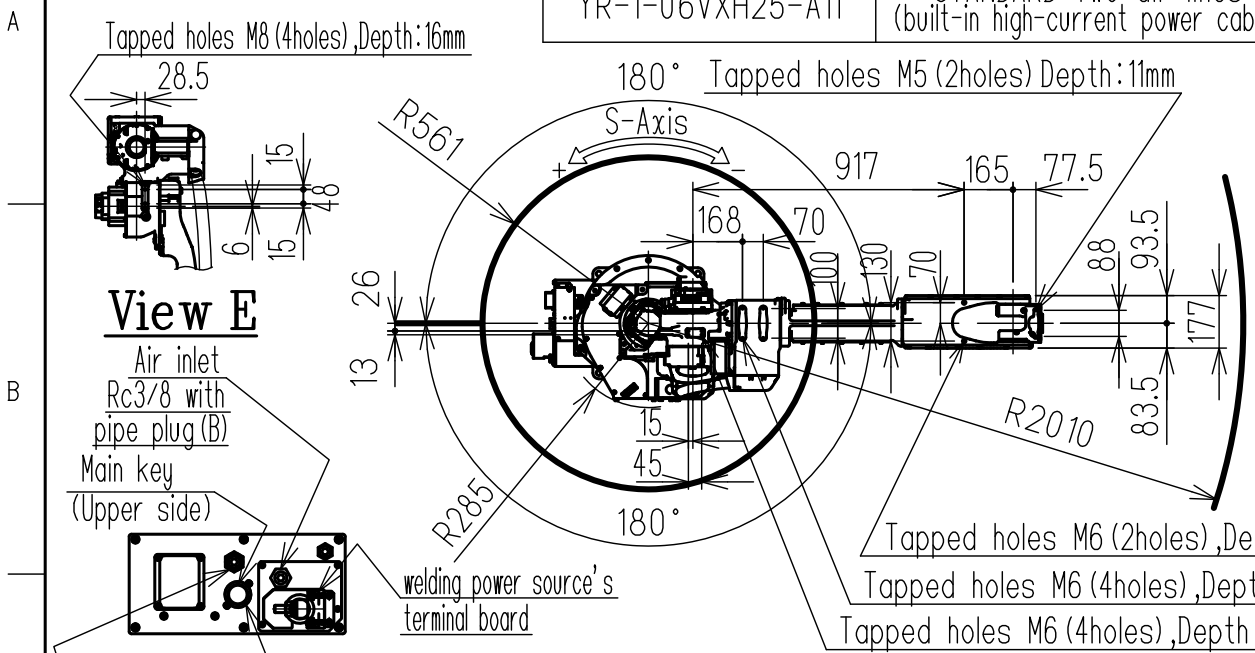

Pins Used

1	(0.2mm ²)
2	(0.2mm ²)
3	(0.2mm ²)
4	(0.2mm ²)
5	(0.2mm ²)
6	(0.2mm ²)
7	+24V (1A)
8	shock sensor (in)
9	(0.2mm ²)
10	(0.2mm ²)
11	(0.75mm ²)
12	(0.75mm ²)
13	(1.25mm ²)
14	(1.25mm ²)
15	(1.25mm ²)
16	(1.25mm ²)

Detail of Internal User Wiring Connector
*Refer to connection diagram for a reserved cable (DWG No. HW0383235) when using the connector: No.7 or No.8.

Item	Model	MOTOMAN-AR2010
Configuration		Vertically articulated
Degree of Freedom		6
Payload	Wrist	12kg
	On U-arm (*1)	9kg
Repeatability (*2)		±0.08mm
Range of Motion	S-Axis	-180° ~ +180°
	L-Axis	-105° ~ +155°
	U-Axis	-86° ~ +160°
	R-Axis	-200° ~ +200°
	B-Axis	-150° ~ +150°
Max Speed	T-Axis	-455° ~ +455°
	S-Axis	3.67rad/s, 210° /s
	L-Axis	3.67rad/s, 210° /s
	U-Axis	3.84rad/s, 220° /s
	R-Axis	7.59rad/s, 435° /s
Allowable Moment	B-Axis	7.59rad/s, 435° /s
	T-Axis	12.2rad/s, 700° /s
	R-Axis	22N·m (2.2kgf·m)
Allowable Inertia (GD ² /4)	B-Axis	22N·m (2.2kgf·m)
	T-Axis	9.8N·m (1.0kgf·m)
	R-Axis	0.65kg·m ²
Approx. Robot mass	B-Axis	0.65kg·m ²
	T-Axis	0.17kg·m ²
	R-Axis	260kg
Protected structure		Body: IP54 Wrist: IP67
Mounting method (*3)		Floor-mounted, Wall-mounted, Tilt-mounted, Ceiling-mounted
Ambient Conditions	Temperature	0 ~ 45°C
	Humidity	20 ~ 80%RH (Non-condensing)
	Vibration	4.9m/s ² (0.5G) or less
	Altitude	1000m or less
Others		•Free from explosive or corrosive gas and liquid. •Free from dust, soot, oil, or water. •Free from electrical noise. •Free from strong magnetic fields.
Power Requirements		2.0KVA
Controller		YRC1000

Notes: *1 Load on the U-arm will vary depending on the load weight of the wrist part.
*2 Repeatability is conformed to ISO 9283.
*3 When the manipulator is installed on a slope or a wall, the motion of S-axis will be limited.
*4 The manipulator is in the home position. Units: mm

Note:
1.All rights reserved.
2.Please note that the data is subject to be deleted without advance notice.
3.No warranty is given in relation to the data including the specification.
4.We are not responsible for any damages or loss caused by the use of the data.

FOR STUDY PURPOSE ONLY

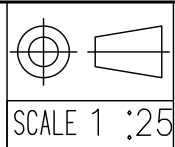

YASKAWA
株式会社 安川電機

Reference Drawing

TITLE MOTOMAN-AR2010
DIMENSION DIAGRAM

DRWN DATE Jul.5.'17
DWG.NO. HW1385612

SIZE A3